

<b>Model No:</b>	<b>Description:</b>
<b>TR-SES 300</b>	<p><b>VUV/UV Transmission and Reflection Evaluation System</b></p> <p>The Resonance Transmission and Reflection Evaluation System uses a computer-controlled tunable vacuum ultraviolet light source with design optimized for test of UV reflectance and transmittance. It delivers vacuum ultraviolet (VUV) wavelengths to samples on a target holder and measures their spectral reflectance and or transmittance with a VUV UV PMT. This is an excellent system for quality control, fundamental research and development of VUV and UV materials.</p> <p>Features include:</p> <ul style="list-style-type: none"> <li>115 to 400 nm tunable light source with 0.1 to 10 nm spectral bandwidth</li> <li>Reference PMT for tunable light source for absolute VUV/UV flux onto sample, reflectance and transmission of sample</li> <li>10 sample positions on motorized wheel</li> <li>Bi-Directional control of incident and reflection angles</li> <li>Modular design allows change of emission sources and sample wheels</li> <li>Compact foot print less than 1 sq. meter</li> <li>Turn-key oil free pumping system</li> </ul>
	

<b>Electrical /Optical Specifications/General:</b>				
Specification	Minimum	Typical	Maximum	units
Excitation Lamps	Deuterium (115-400 NM) standard			
Excitation Monochromator	320 mm focal length f 6 concave holographic grating spectrometer			
Excitation wavelength range	115 to 400			
Excitation wavelength resolution	0.1 to 10 nm selectable with slit size			
Output beam collimator	2 cm collimated beam or smaller			
Target holder	10 25 mm samples, variable tilt, variable angle PMT for VUV/UV transmission and intensity			
System	Complete system includes D2 lamp, 300 mm VUV/UV monochromator adjustable slits, parabolic collimator, beam size control, sample wheel with bi-directional (BDF) reflectance capability, PMT for 115 to 400 nm Reflectance and transmission measurements, all control electronics and power supplies including PC and Vacuum flange and pump			
Vacuum pump	Turbo plus diaphragm station (15 to 30 minute pump out time) to pressures in 10(-5) torr range. (Suitable for VUV in 115 to 200 nm range). Ultimate vacuum 10(-7) torr			

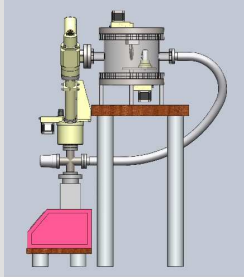
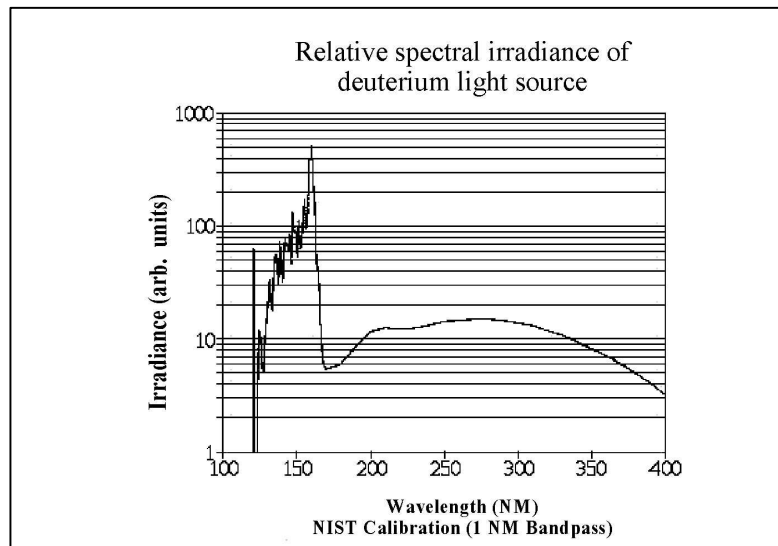
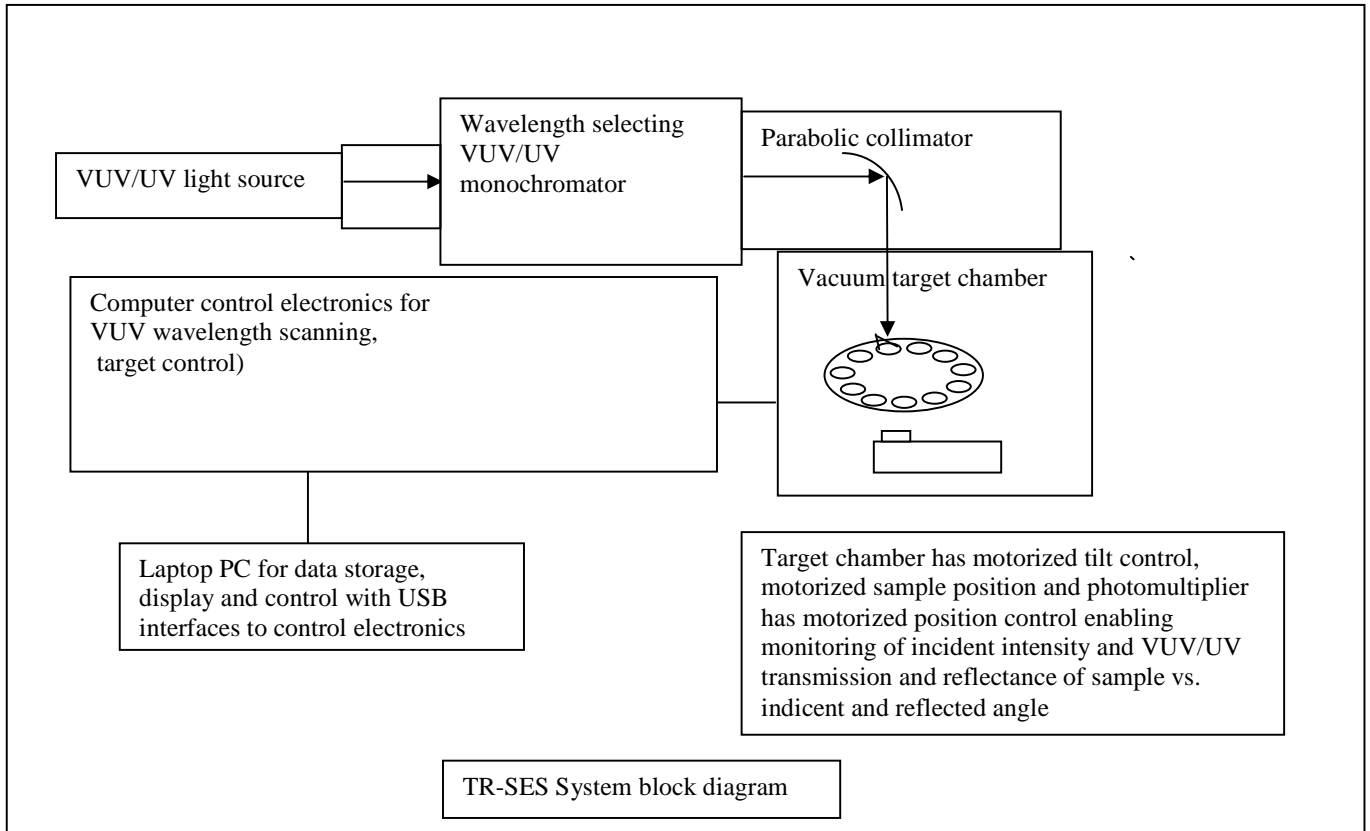
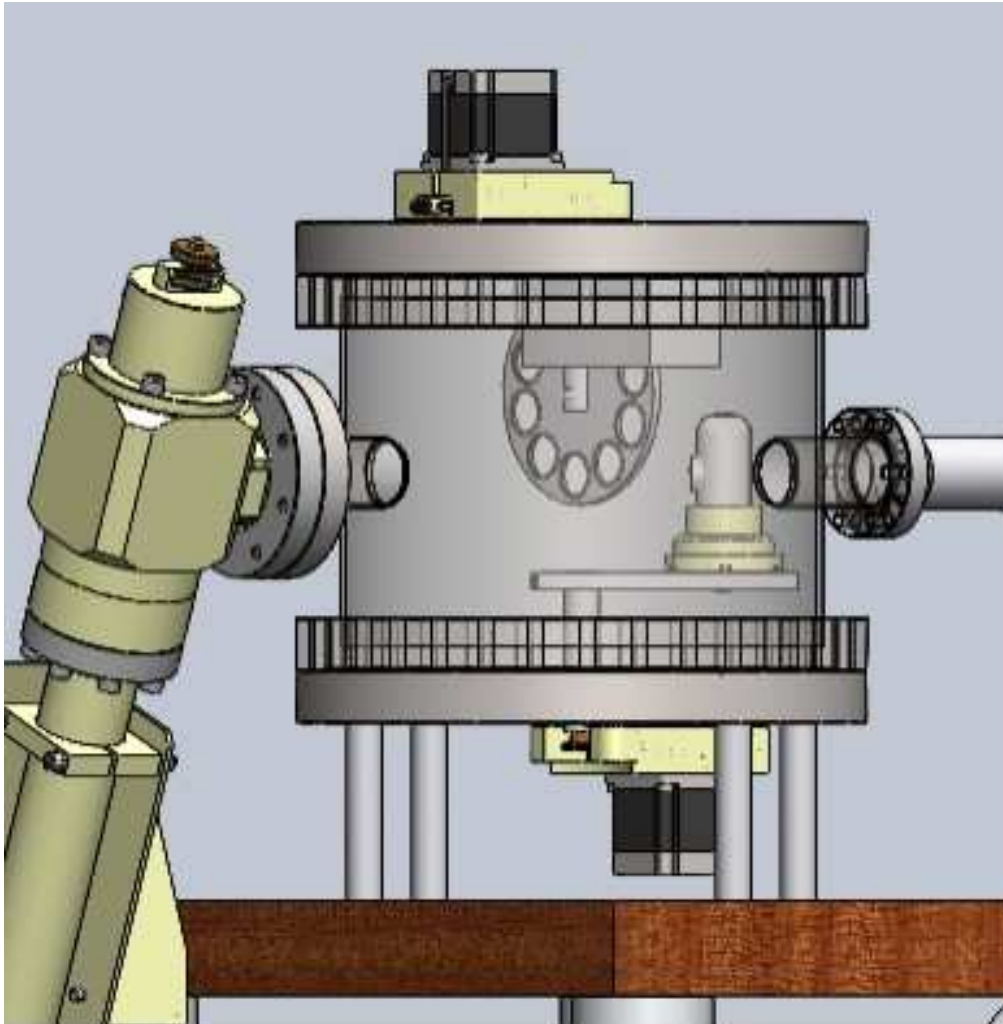

Fig: 1 Resonance Standard D2 spectrum from 115 to 400 nm by NIST



**Figure 2: Tunable light source for TR-SES (note PMT on left top is placed inside sample chamber shown below)**



**Figure 3: TR-SES sample chamber with PMT and sample wheel with vacuum drives**

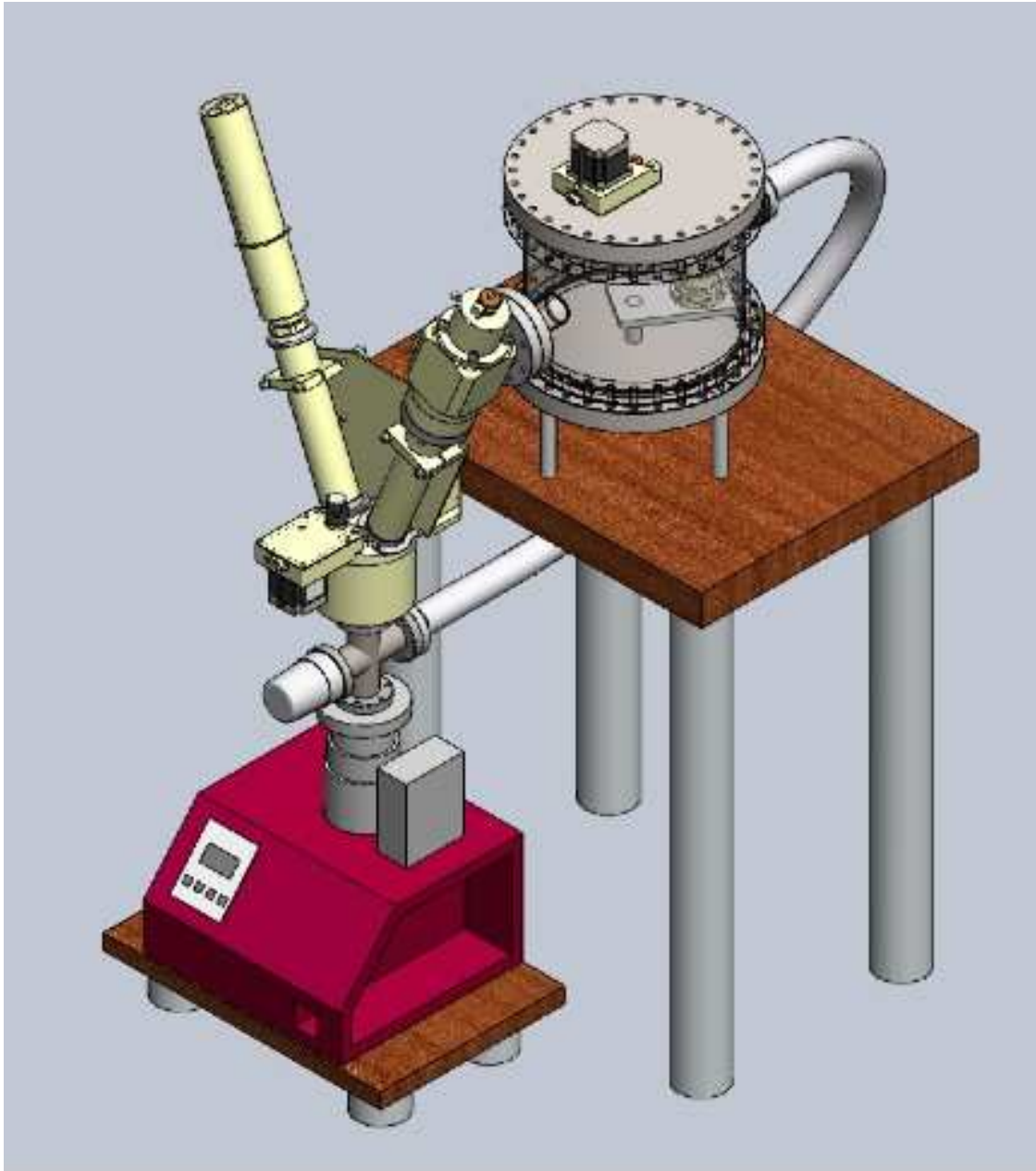

Figure 4: TR-SES isometric view